

UTILITY CONDUIT

(UCC37-75)

For the installation of
multi-directional air sampling pipe
to threaded rod.
360° clip swivel.

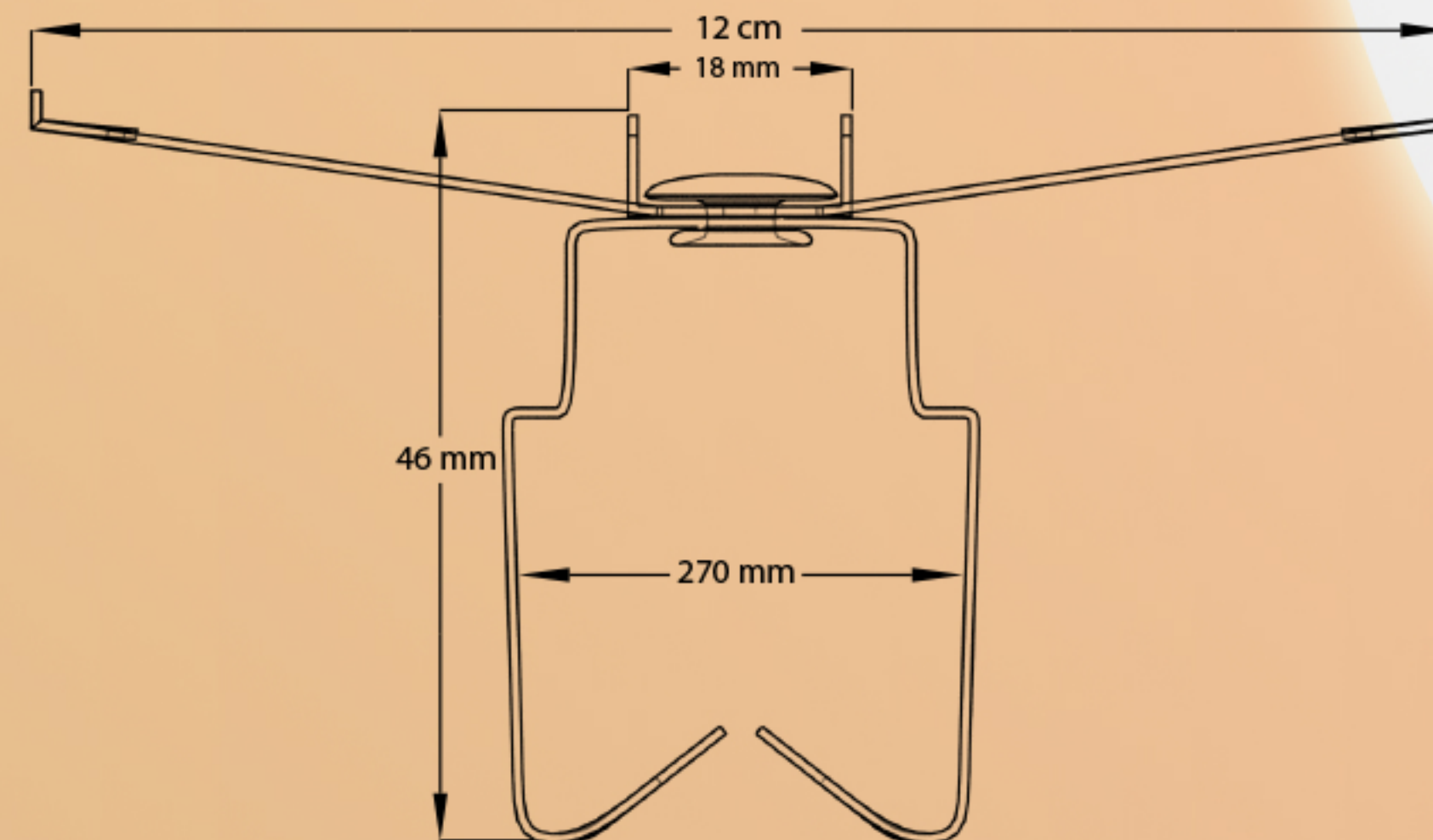
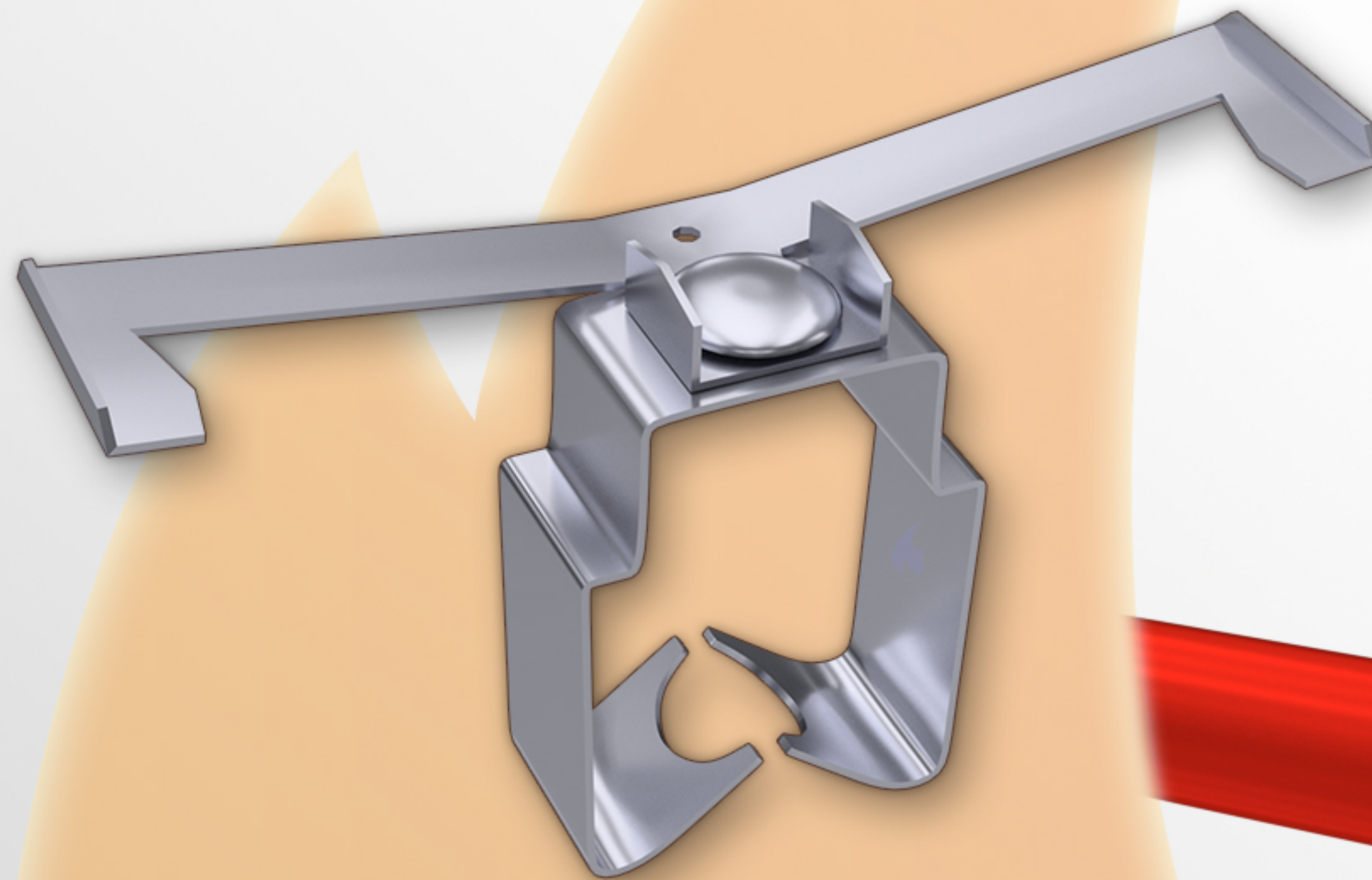

Part No.
Clip Material
Diameter
Rod Thickness

UCC37-75
SPRING STEEL
25-27mm
M10-M12

RAW MATERIAL DATA

Spring Steel (Type C570)

Surface treatment: Delta-Tone 9000
(480 hours)

Yield Point -
407 - 426 N / QMM

Tensile Strength -
576 - 590 N / QMM

Elongation A80 -
21.8 - 25.8 %

Hardness HV -
167 - 171

Melt Chemistry
No. 5843

C	- 0.726
SI	- 0.259
MN	- 0.650
P	- 0.013
S	- 0.001
AL	- 0.006
CR	- 0.073
MO	- 0.007
NI	- 0.047

Quality and Dimension

Cold rolled steel strip
C675 LC MA-RL NK
EN 10132-4 / EN 10140
or as shown below
HV 185 max.
In coils, oiled, id 500 mm, od max.
1.050 mm, coilweight max. 3.000 kg,
Poly wrapped, on wooden skids,
bundleweight max. 5.000 kg

1.00 x 547	mm
Thickness tol. +/- 0.030	mm
Width tol. +5/-0	mm

Incoterms 2010: DAP
Tariff-no. 72112900

Inspection certificate 3.1
Acc. DIN EN 10 204
No. 91571 / 011

For use with static loads only.

Fire Suppression Limited
Unit 11, Eldonwall Trading Estate,
St.Phillips, Bristol, BS4 3QQ

Tel: 0845-127-9915
Fax: 0845-127-9959
sales@firesuppression.co.uk