

EQUAL TEE

(ABSG006 - 25mm)

This device is used when a "Bull nose" or "Side tee" flow split is required. This device aspirating fire detection only

Installation Instructions:

Do not paint.
Keep pipe clean and free from dust.
Do not install in direct sunlight.
Only install with approved pipe and fittings.
Do not use solvents to clean, only soapy water.

Part No. ABSG006
Fitting Colour GREY
Diameter Tolerance +/- 0.15mm

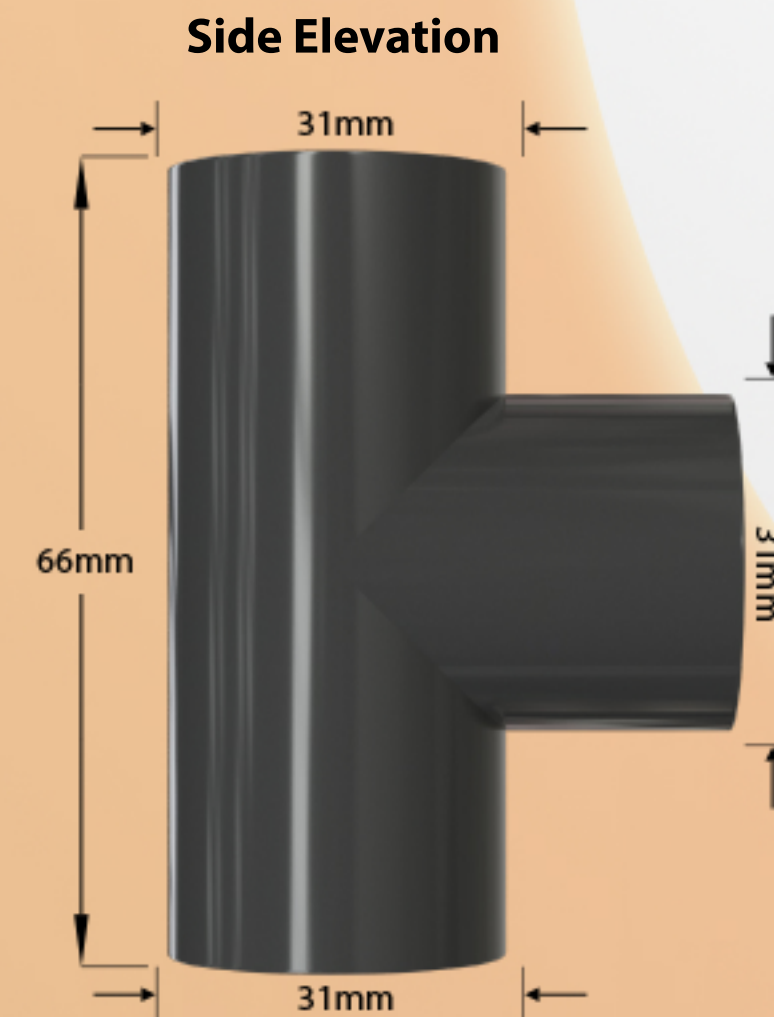
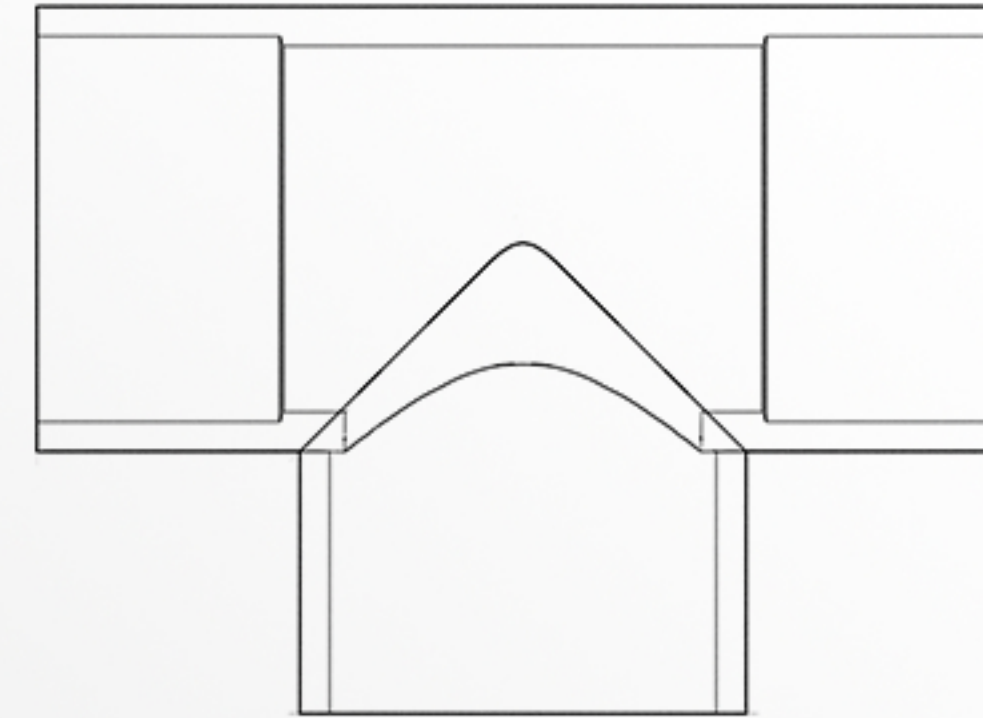
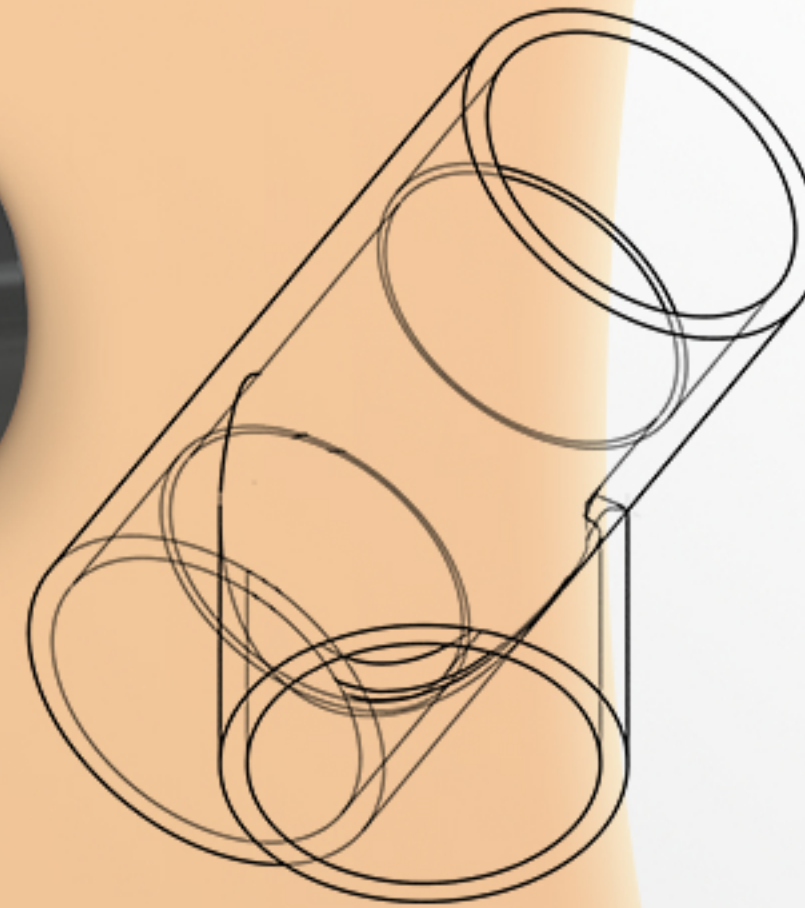
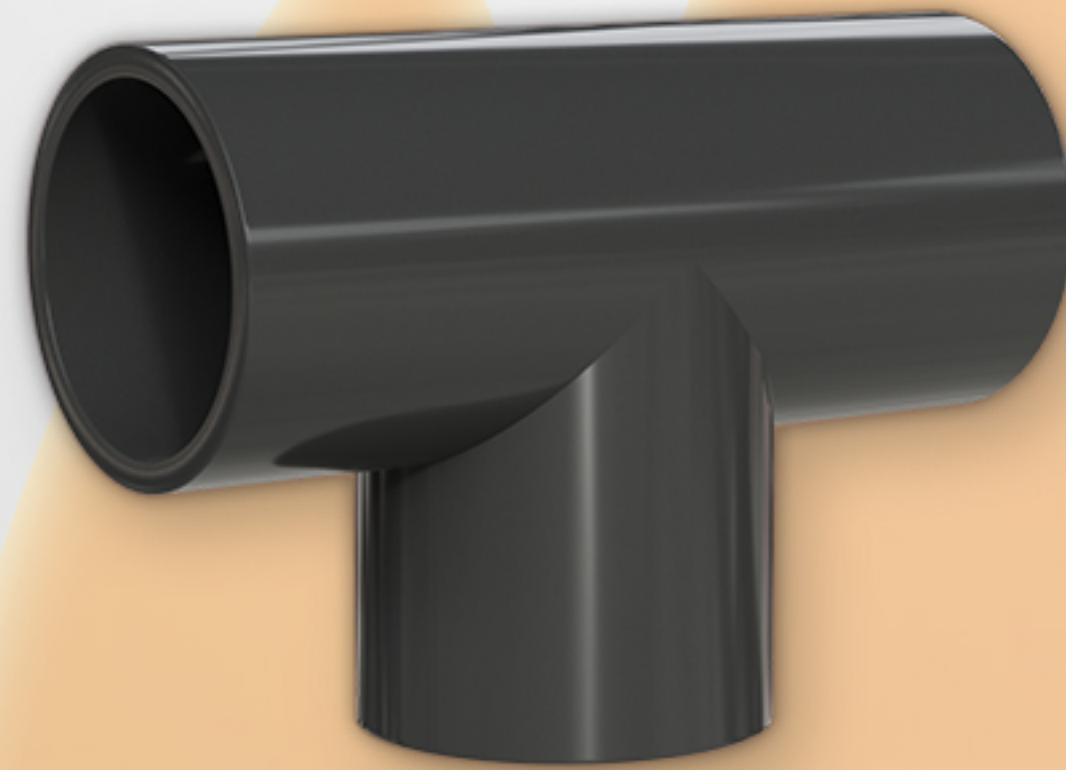

RAW MATERIAL DATA

Kumho ABS 750
Acrylonitrile Butadiene Styrene

Physical:
Specific Gravity 1.04
Test Method ASTM D792

Melt Mass - Flow Rate (MFR)
200°C/21.6 kg 47 g/10 min
200°C/5.0 kg 4.1 g/10 min
220°C/10.0 kg 34 g/10 min
Test Method ASTM D1238

Molding Shrinkage -
Flow 0.0040 to 0.0070 in/in
Test Method ASTM D955

Mechanical:
Tensile Strength
Yield, 73°F (23°C)
1.97 in (50.0mm)
6670 psi
Test Method ASTM D638

Tensile Elongation
Yield, 73°F (23°C)
1.97 in (50.0 mm), 15%
Test Method ASTM D638

Flexural Modulus
Yield, 73°F (23°C)
0.118 in (3.00 mm)
312000 psi
Test Method ASTM D638

Flexural Strength
Yield, 73°F (23°C)
0.118 in (3.00 mm)
9230 psi
Test Method ASTM D790

Impact
Notched Izod Impact
73°F(23°C), 0.126 in (3.20 mm), 5.5 ft-lb/in
73°F(23°C), 0.252 in (6.40 mm), 4.8 ft-lb/in
Test Method ASTM D256

Hardness
Rockwell Hardness (R-Scale) 108
Test Method ASTM D785

Thermal
Deflection Temperature Under Load
264 psi (1.8 MPa), Unanneald 185°F/85°C
Test Method ASTM D648

Vicat Softening Temperature 203°F/95°C
Test Method ASTM D1525

Flamability
Flame Rating
0.0630 in (1.60 mm) HB
0.0866 in (2.20 mm) HB
0.126 in (3.20 mm) HB
Test Method UL 94

Fire Suppression Limited
Unit 11, Eldonwall Trading Estate,
St.Phillips, Bristol, BS4 3QQ

Tel: 0845-127-9915
Fax: 0845-127-9959
sales@firesuppression.co.uk